

MISCELATORE MONOCOMANDO PER LAVABO CON BOCHELLO ESTRAIBILE

| Articolo | Item | |
|----------------------------------------------------------------------------------------------------------------------------------------------------------------------------------------------------------------------------------------------------------------------------------------------------------------------------------------------------|------------------------------------------------------------------------------------------------------------------------------------------------------------------------------------------------------------------------------------------------------------------------------------------------------------------------|-------------------------------------------------------------------------------------|
| NS98650 | NS98650 |  |
| MISCELATORE MONOCOMANDO PER LAVABO BOCHELLO ESTRAIBILE | BASIN MIXER PULL-OUT FAUCET | |
| <ul style="list-style-type: none"> • Corpo in ottone cromato • Funzionamento a dischi ceramici • Ingresso 3/8" • Flessibile collegamento bocchello cm 120 • Flessibile bocchello con peso. • Pressione di esercizio min 1 max 5 bar • Temperatura di esercizio min 5 max 65°C | <ul style="list-style-type: none"> • Body in chrome-plated brass • with ceramic discs Operated • Inlet 3/8" • Connecting hose spout cm 120 • Nozzle hose with weight. • Working pressure min 1 max 5 bar • Operating temperature min 5 max 65 ° C | |

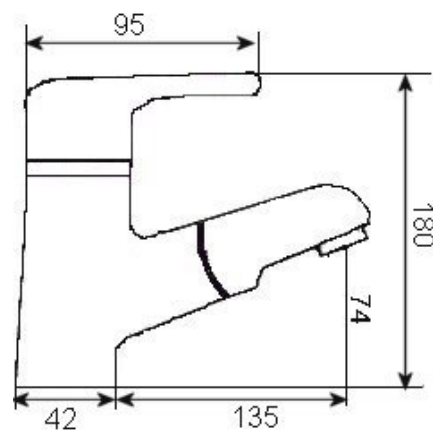

Misure, quote e specifiche non sono vincolanti e l'azienda si riserva di modificarle in qualunque momento anche senza preavviso. Non rilevare quote dai disegni